



رقم الصادر ١٤٣٧/٠١/١٦ تاريخ الصادر

المرفقات لله



بِسْمِ اللَّهِ الرَّحْمَنِ الرَّحِيمِ



www.customs.gov.sa

المملكة العربية السعودية  
وزارة الجمال والتجارة  
مصلحة الجمارك العامة

إدارة البرامج والاتفاقيات الدولية  
( ١٨٤ )

KINGDOM OF SAUDI ARABIA

Ministry of Finance

Saudi Customs General

Ref. : .....

Date : 14/01/1437 AH

27/10/2015 AG

Mr. Neşet AKKOÇ,  
Undersecretary,  
Ministry of Customs and Trade,  
Ankara, Republic of Turkey

سعادة الأستاذ نشأت أكوج  
وكيل وزارة الجمارك والتجارة  
أنقرة - جمهورية تركيا

السلام عليكم ورحمة الله وبركاته ...

Dear Mr. AKKOÇ,

I avail this opportunity to advise you that the competent authority in the Kingdom of Saudi Arabia (i.e., Saudi Standards, Metrology and Quality Organization (SASO) has issued technical specifications for Motor vehicles – front, rear and lateral protective devices in trucks and its methods of test in accordance with the standards issued by SASO viz., SASO GSO 2112:2012, SASO GSO 2113:2012 and SASO GSO 2114:2012.

أود إفادة سعادتكم بأن الجهة المختصة بالمملكة العربية السعودية (الهيئة السعودية للمواصفات والمقاييس (SASO)) أصدرت لوائح فنية خاصة لحواجز الحماية الأمامية والجانبية والخلفية للشاحنات والمقطورات طبقاً للمواصفة الصادرة من الهيئة السعودية للمواصفات والجودة (ساسو) رقم "SASO GSO 2112:2012" ورقم "SASO GSO 2113:2012" ورقم "SASO GSO 2114:2012".

Compulsory application of such standards shall begin effective 01/07/1437 AH corresponding to 08/04/2016 AG. Three booklets containing such technical standards enclosed herewith, are mailed through express courier. You may also obtain them from the Saudi Standards, Metrology and Quality Organization (SASO) website. We hope you to kindly convey to the competent authorities and those concerned with the land transport activities at the Republic of Turkey that the Saudi Customs shall not allow entrance of the trucks and trailers arriving or transiting the territory of the Kingdom of Saudi Arabia, if not complying with the above-mentioned standards effective the dates indicated above.

وسوف يتم البدء في تطبيق المواصفات بشكل إلزامي اعتباراً من ١٤٣٧/٧/١ هـ الموافق ٢٠١٦/٤/٨ م ... وتجدون بطيه ثلاثة كتيبات تشمل على تلك المواصفات الفنية مرسله عبر البريد السريع، كما ويمكن لكم الحصول عليها من موقع الهيئة السعودية للمواصفات والمقاييس ... نأمل إبلاغ الجهات المختصة والمهتمين بنشاط النقل البري بالجمهورية التركية بأن الجمارك السعودية لن تسمح بدخول الشاحنات والمقطورات القادمة أو العابرة لأراضي المملكة التي لا تتقيد بالمواصفات القياسية المذكورة أعلاه اعتباراً من التاريخ المشار إليه أعلاه ... وتقبلوا خالص التحية والتقدير...

Please accept our kindest regards.

Sincerely Yours,

صالح بن منيع الخليوي  
مدير عام الجمارك السعودية  
Saleh M. S. AIKhalawi  
Director General of Saudi Customs

المملكة العربية السعودية  
KINGDOM OF SAUDI ARABIA

الهيئة السعودية للمواصفات والمقاييس والجودة  
Saudi Standards, Metrology and Quality Org.(SASO)

**SASO GSO 2112:2012**

السيارات - حواجز الحماية الأمامية للشاحنات وطرق اختبارها

**Motor vehicles-front under run protective devices in  
trucks and its methods of test**



المواصفات القياسية السعودية  
**SAUDI STANDARDS**

السيارات - حواجز الحماية الأمامية للشاحنات وطرق اختبارها  
**Motor vehicles-front under run protective devices in  
trucks and its methods of test**

التصنيف الدولي للمواصفات

تاريخ الاعتماد من مجلس الإدارة : ١٤٣٤/٢/١٢ هـ الموافق ٢٠١٢/١٢/١٦ م  
تاريخ النشر في الجريدة الرسمية: ١٤٣٤/٤/٥ هـ الموافق ٢٠١٣/٢/١٦ م  
تاريخ العمل بلائحة : ١٤٣٥/٤/٥ هـ الموافق ٢٠١٤ / ٢ / ٦ م

Motor vehicles -  
Front underrun protection in truck and its methods of test

1- SCOPE AND FIELD OF APPLICATION

This standard is concerned with the requirements for the front underrun protective devices (FUPD) of trucks having maximum mass exceeding 3.5 tones used for the carriage of goods. This standard does not apply to off road vehicles and vehicles such that their use is incompatible with the provisions of front underrun protection.

2- COMPLEMENTARY REFERENCES

2.1 GSO 159 “Motor Vehicles - Weights and Dimensions”.

2.2 GSO 48 “Motor Vehicles - Conformity Certificates”.

3- DEFINITIONS

3.1 Maximum mass : The mass stated by the vehicle manufacturer to be technically permissible.

3.2 Maximum weight : The vertical force (in newtons) required to support the same vehicle loaded to its maximum mass.

3.3 Unladen Vehicle: The vehicle in running order unoccupied and unladen but complete with fuel, coolant, lubricant, tools and a spare wheel.

3.4 Type of FUPD : FUPD which do not differ with respect to the essential characteristics such as shape, dimensions, attachment, materials and the markings.

3.5 Front Underrun Protection (FUP) : The presence at the front of the vehicle of either: a special FUPD or a body work, chassis parts or other components such that by virtue of their shape and characteristics, these elements can be regarded as fulfilling the function of the FUPD.

4- REQUIREMENTS

The following shall be met:

4.1 General

4.1.1 All vehicles carrying goods, including tankers, mobile cranes, mobile workshops of maximum mass exceeding 3.5 tonnes, shall be equipped with front underrun protective devices to offer effective protection for passenger cars or vehicles carrying goods having maximum mass not exceeding 3.5 tonnes against underrunning in the event of a frontal collision.

- 4.1.2 The front underrun protective device shall comply with the requirements specified in item 4.2.
- 4.1.3 If the vehicle is so designed and equipped at the front that by virtue of their shape and characteristics, its component parts comply with the requirements specified in items 4.2 and 4.3, then the vehicle may not be necessary to be provided with front underrun protective device.
- 4.1.4 The maximum mass of a vehicle type for which the front underrun protective device to be installed shall not exceed the value indicated on the front underrun protective device for which it is designed for.
- 4.1.5 Vehicles of a maximum mass not exceeding 7.5 tonnes shall comply only with the ground clearance requirement of 400 mm set out in this Regulation.
- 4.2 FUPD Technical requirement
- 4.2.1 The FUPD shall offer adequate resistance to forces applied parallel to the longitudinal axis of the vehicle and also satisfy certain dimensional requirements. These shall be checked in accordance with the test procedure and conditions specified in this Regulation.
- 4.2.2 The section height of the FUPD cross-member shall not be less than 100 mm for goods vehicles having a maximum mass between 3.5 and 12 tones and 120 mm for goods vehicles having maximum mass exceeding 12tones.
- 4.2.3 The lateral extremities of the cross-member shall not bend to the front or have a sharp outer edge; this condition is fulfilled when the lateral extremities of the cross-member are rounded on the outside and have a radius of curvature of not less than 2.5 mm.
- 4.2.4 The device may be so designed that its position at the front of the vehicle can be varied. In this event, there shall be a guaranteed method of securing it in the service position so that any unintentional change of position is precluded.
- 4.2.5 It shall be possible for the operator to vary the position of the device by applying a force not exceeding 40 daN;
- 4.2.6 The outermost surfaces of every front guard installation shall be essentially smooth or horizontally corrugated so that domed heads of bolts or rivets may protrude beyond the surface to a distance not exceeding 10 mm.
- 4.3 Installation of FUPD

- 4.3.1 The maximum mass of a vehicle type shall not exceed the value indicated on the approved FUPD intended to be installed on that vehicle.
- 4.3.2 The vehicle with the FUPD installed shall satisfy the dimensional requirements specified in item 6.3 of this regulation taking into account the test conditions and information indicated on this regulation in respect of the FUPD.
- 4.3.3 The FUPD shall be so fitted to the vehicle that the horizontal distance measured in the rearward direction from the foremost part of the vehicle to the front of the FUPD does not exceed 400 mm diminished by the recorded deformation measured at any of the points where the test forces have been applied during the test of the FUPD in conformity with the provisions of this regulation .
- 4.3.4 In measuring the distances, any part of the vehicle which is more than 2 m above the ground shall be excluded.
- 4.3.5 The maximum ground clearance with respect to the underside of the FUPD shall be no more than 400 mm, between the two points (P1) in the installed condition.(Fig 2)
- 4.3.6 Outboard of each point (P1) of the above mentioned height may be greater than 400mm providing the underside is not above a plane passing through the underside of the FUPD directly below the point (P1)and forming a slope at 15° above the horizontal (Fig 2)
- 4.3.7 The height above the ground of the points of application of the test forces applied to the FUPD shall not exceed 445 mm
- 4.3.8 The maximum ground clearance with respect to the underside of the FUPD between the two points (P1) shall be no more than 450 mm taking into account their movement during the application of the test load.
- 4.3.9 The width of the FUPD shall at no point exceed the width of the mudguards covering the wheels of the foremost axle nor shall it be more than 100 mm shorter
- o

than 3.5 tonnes against under running, provided that the vehicle is equipped with an FUPD which has not been separately approved for this Regulation or is so designed and/or equipped at the front that, by virtue of their shape and characteristics, its component parts can be regarded as replacing the front underrun protective device.

- 4.4.2 Components whose combined function satisfies the following requirements are considered to form a front underrun protective device.
- 4.4.3 The FUP shall offer adequate resistance to forces applied parallel to the longitudinal axis of the vehicle.
- 4.4.4 The FUP shall satisfy the dimensional requirements indicated in item 6.3 of this regulation.
- 4.4.5 The section height of the FUPD cross-member not separately approved shall not be less than 100 mm for goods vehicles having a maximum mass between 3.5 and 12 tonnes and 120 mm for vehicles having maximum mass exceeding 12 tonnes
- 4.4.6 The device may be so designed that its position at the front of the vehicle can be varied. In this event, there shall be a guaranteed method of securing it in the service position so that any unintentional change of position is precluded.
- 4.4.7 It shall be possible for the operator to vary the position of the device by applying a force not exceeding 40 daN;
- 4.4.8 The FUP shall have sufficient strength that the horizontal distance measured in the rearward direction between the foremost part of the vehicle after the application of the test forces and the test ram contact surface on the vehicle does not exceed 400 mm ( item 6.3).
- 4.4.9 In measuring the distances, any part of the vehicle which is more than 2 m above the ground shall be excluded.
- 4.4.10 The maximum ground clearance with respect to the underside of the FUP shall be no more than 400 mm between the two points P1 (Fig 2)
- 4.4.11 This height may be greater than 400 mm providing the underside is not above a plane passing through the underside of the FUP directly below the point P1 and forming a slope at 15° above the horizontal (Fig 2)
- 4.4.12 The maximum ground clearance with respect to the underside of the FUP between the two points P1 shall be no more than 450 mm taking into account their movement during the application of the test load.

- 4.4.13 The width of the FUP shall at no point exceed the width of the mudguards covering the wheels of the foremost axle nor shall it be more than 100 mm shorter on either side than the foremost axle measured at the outermost points of the tyres, excluding the bulging of the tyres close to the ground ( Fig 1), or 200 mm shorter on either side, measured from the outermost points of the access steps to the driver's cabin.
- 5- MARKING
- 5.1 Each front underrun protective device shall be legibly and durably marked or labelled with the following information in Arabic and/or English.
- 5.1.1 Manufacturers name and/or trademark.
- 5.1.2 Date of manufacture.
- 5.1.3 The maximum mass of vehicle on which the front underrun protective device may be installed.
- 5.1.4 A detailed description with sketches the correct installation and adjustment of the device.
- 5.1.5 Drawings, diagrams and layout plans of the components of the structure.
- 6- TESTING
- 6.1 Sampling
- A sufficient number of front underrun protective devices shall be taken from the consignment of the devices of the same type and subjected to the required tests prescribed in this standard.
- 6.2 Measuring instruments
- 6.2.1 Dimension measuring instrument
- The instruments used shall permit measurement to an accuracy of ( $\pm 1$ ) mm.
- 6.2.2 Force measuring instruments
- The instruments used shall permit measurement to an accuracy of  $\pm 5\%$  of the range.
- 6.3 Tests
- The following tests shall be carried out on the sample withdrawn in accordance with item 6.1.
- 6.3.1 Visual inspection



The front underrun protective device shall be visually examined to check for any damage, crack, sharp outer edge or any apparent defects.

### 6.3.2 Test conditions for FUPD

#### 6.3.2.1 The test may be carried out either:

- On a vehicle of the type for which FUPD is intended
- On a part of the chassis of the vehicle type for which the FUPD is intended, this part shall be representative of the vehicle type in question
- On a rigid test bench

#### 6.3.2.2 Test conditions for vehicles.

- The sample shall be installed on to a vehicle of the type for which the front underrun protective device is intended or part of the chassis or on a rigid bench..
- The vehicle shall be restrained by a suitable method as specified by the manufacturer to or restrained by any method specified by the manufacturer.
- The dimensions shall be taken as if the vehicle were in the following condition:
  - The vehicle shall be at rest on a level, flat, rigid and smooth surface.
  - The front steered wheels shall be in the straight-ahead position.
  - The vehicle shall be unladen.
  - The tyres shall be inflated to the pressure recommended by the vehicle manufacturer.
  - Vehicles equipped with hydro-pneumatic, hydraulic or pneumatic suspension or a device for automatic leveling according to load, shall be tested in the normal running condition specified by the manufacturer.

#### 6.3.2.3 Procedure

The measurements shall be made on the front underrun protective device installed in accordance with item 6.3.2.1 and in compliance with items 6.3.2.2

### 6.3.3 Strength test

#### 6.3.3.1 Apparatus

- The apparatus shall consists of a rams which are suitably articulated (e.g. by means of universal joints) and shall be parallel to the median longitudinal plane of

the vehicle via a surface not more than 250 mm in height indicated by the manufacturer.

- The surface shall not be more than 400 mm wide, with a radius of curvature of  $(5 \pm 1)$  mm at the vertical edges.
- The centre of the surface is placed successively at points P1, P2 and P3 (fig 1)

#### 6.3.3.2 Preparation for the test

The vehicle shall be prepared for the tests as explained in item 6.3.2.2.

#### 6.3.3.3 Procedure

6.3.3.3.1 Points P1 are located up to 200 mm from the longitudinal planes tangential to the outermost points of the tyres on the front axle, excluding the bulging of the tyres close to the ground; points P2 are symmetrical to the median longitudinal plane of the vehicle at a distance from each other of 700 to 1,200 mm inclusive. The exact positions shall be specified by the manufacturer.

6.3.3.3.2 The height above the ground of points P1 and P2 shall be defined by the vehicle manufacturer within the lines that bound the front face of the device. The height shall not, however, exceed 445 mm when the vehicle is unladen. P3 is in the vertical longitudinal median plane of the vehicle ( Fig 1 )

6.3.3.3.3 The test forces set out below shall be applied to each of the test points in separate tests on the same vehicle or device or, if requested by the manufacturer, on different vehicles or device samples.

- If the structure and components of the vehicle relevant to the front underrun protection are located substantially symmetrical to its longitudinal median plane the tests at points P1 and P2 shall be carried out only on one side.
- When tested the forces shall be applied as rapidly as possible and the device or vehicle shall withstand the forces in the items mentioned below for at least 0.2 seconds.
- A horizontal force equal to 50% of the maximum weight of the vehicle or intended vehicle type(s) but not exceeding  $80 \times 10^3$  N shall be applied successively to both points P1
- A horizontal force equal to 100% of the maximum weight of the vehicle or intended vehicle type(s) but not exceeding  $160 \times 10^3$  N shall be applied successively to both points P2.

- If the device is discontinuous and is reduced in cross-section area between the two points P2, then the tests shall continue with the application of a horizontal force applied to the point P3 the same as that to the points P1.

6.3.3.3.4. The maximum horizontal and vertical displacements of each test point during the application of the above forces shall be recorded and the highest value recorded on the test report or the document supplied with the device.

#### 6.3.3.4 Result

At the end of each test the distance between the rear of the front underrun protective device and the front extremity of the vehicle at any of the points shall be measured.

### 7- CRITERIA OF TECHNICAL CONFORMITY

7.1 The criteria of technical conformity shall be in accordance with the Gulf Standard GSO 48/1984 "Motor Vehicles - Conformity Certificates".

7.2 The front underrun protective device shall be considered complying with all the requirements of this regulation when the withdrawn sample from the consignment or the supplied sample by the manufacturer passes the tests.

7.3 In case one or more front underrun protective device in the sample fails to pass the tests, a second sample double the number of units as the first one shall be withdrawn from the same consignment or the supplied sample and subjected to the tests.

The front underrun protective device shall be considered complying with the requirements of this regulation when all the units of the second sample pass the tests, otherwise the front underrun protective device shall be considered non-complying.

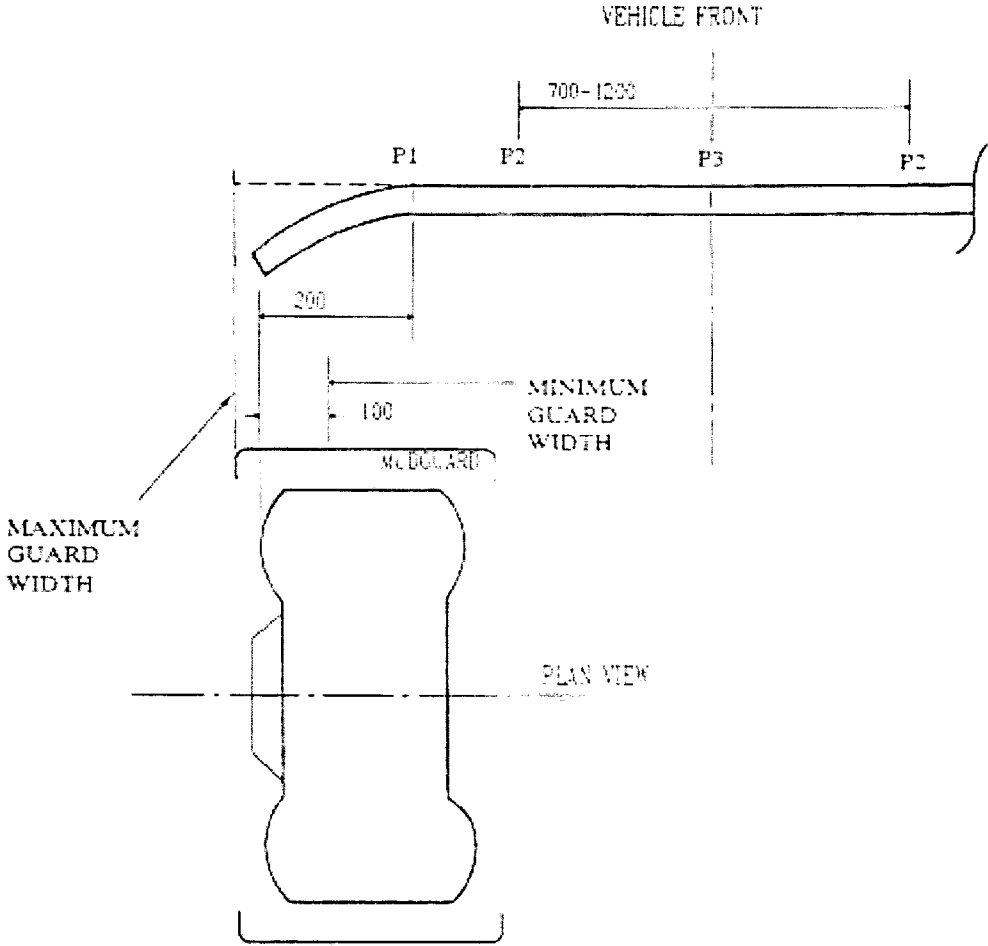

FUP NORMALLY CONSISTS OF A CROSS-MEMBER AND LINKS TO THE CHASSIS OR OTHER STRUCTURAL MEMBERS

Note: The shape of FUPD is only an example.

Fig 1

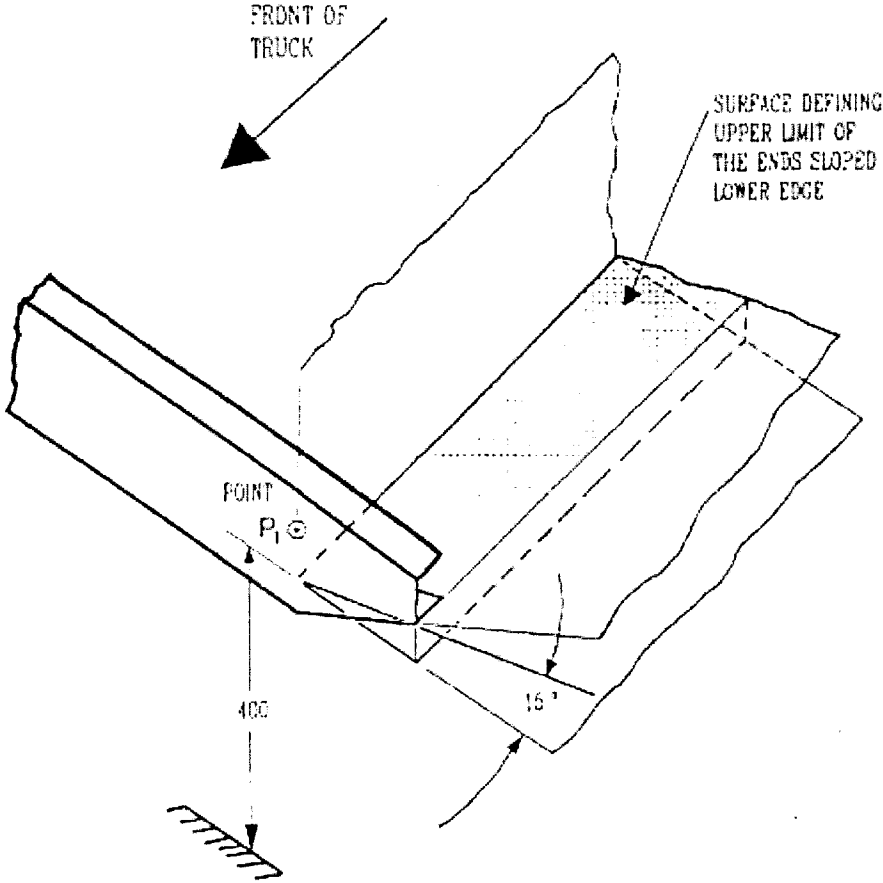

Fig 2

المملكة العربية السعودية  
KINGDOM OF SAUDI ARABIA

الهيئة السعودية للمواصفات والمقاييس والجودة  
Saudi Standards, Metrology and Quality Org.(SASO)

**SASO GSO 2113:2012**

السيارات - الحماية الجانبية للشاحنات والمقطورات وطرق اختبارها

**Motor vehicles-lateral protection of truck and trailer  
and its methods of test**



المواصفات القياسية السعودية  
**SAUDI STANDARDS**

**السيارات - الحماية الجانبية للشاحنات والمقطورات وطرق اختبارها**  
**Motor vehicles-lateral protection of truck and trailer**  
**and its methods of test**

التصنيف الدولي للمواصفات

تاريخ الاعتماد من مجلس الإدارة : ١٤٣٤/٢/١٢ هـ الموافق ٢٠١٢/١٢/١٦ م  
تاريخ النشر في الجريدة الرسمية: ١٤٣٤/٤/٥ هـ الموافق ٢٠١٣/٢/١٦ م  
تاريخ العمل بلانحة : ١٤٣٥/٤/٥ هـ الموافق ٢٠١٤ / ٢ / ٦ م

## Motor vehicles - Lateral protection of truck and trailer and its methods of test

### 1- SCOPE AND FIELD OF APPLICATION

This regulation is concerned with the requirements for the lateral protection (side guards) of trucks and trailers having maximum mass exceeding 3.5 tones used for the carriage of goods.

This regulation does not apply to tractors for semi trailers and vehicles designed and constructed for special purposes where it is not possible for practical reasons to fit such lateral protection

### 2- COMPLEMENTARY REFERENCES

2.1 GSO 159 "Motor Vehicles - Weights and Dimensions".

2.2 GSO 48 "Motor Vehicles - Conformity Certificates".

### 3- DEFINITIONS

3.1 Motor vehicle: A vehicle, excluding motor cycles or trailers, operated by means of a motor without dependence on rails, cables or similar guides.

3.2 Truck: A motor vehicle intended for carrying goods. It may also tow a trailer.

3.3 Maximum weight: The weight stated by the vehicle manufacturer to be technically permissible.

3.4 Approval of a vehicle: The approval of a complete vehicle type with regard to its lateral protection;

3.5 Vehicle type : A category of vehicles which do not differ with respect to the essential points such as the width of the rear axle, the overall width, the dimensions, the shape and the materials of the whole side of the vehicle (including the cab if fitted), and the characteristics of the suspension in so far as they have a bearing on the technical requirements specified in this Regulation.

3.6 Maximum mass : The mass stated by the vehicle manufacturer to be technically permissible (this mass may be higher than the "permissible maximum mass" laid down by the national administration);

3.7 Unladen mass: The weight of the vehicle in running order, unoccupied and unladen, but complete with fuel, coolant, lubricant, tools and spare wheel, if supplied by the vehicle manufacturer as standard equipment;

3.8 Unprotected road users: The pedestrians, cyclists or motor cyclists using the road in such a way that they are liable to fall under the sides of the vehicle and be caught under the wheels.

### 4- REQUIREMENTS

The following shall be met.

#### 4.1 General

4.1.1 All vehicles carrying goods, including tankers, mobile cranes, mobile workshops, trailers and semi-trailers shall be constructed and equipped in such a way as to



offer, throughout their length, at both sides effective protection to unprotected road users against the risk of falling under the sides of the vehicle and being caught under the wheels. This shall be complied by providing one of the following:

- 4.1.1.1 The vehicle is equipped with a special lateral protective device (side guards) according to the technical requirements specified in item 4.2.or
- 4.1.1.2 If the vehicle is so designed and/or equipped at the side that by virtue of their shape and characteristics, its component parts can be incorporated and/or regarded as replacing the lateral protective device and comply with the requirements specified in item 4.2.
- 4.2 Technical
- 4.2.1 The side guard shall not increase the overall width of the vehicle.
- 4.2.2 The main part of side guard's outer surface shall not be more than 120 mm in board from the outer most plane of the vehicle.
- 4.2.3 The side guards forward end may be turned inwards in accordance with the requirements mentioned below.
- 4.2.4 The side guard's rearward end shall not be more than 30 mm in board from the outermost edge of the rear tyres over at least the rearmost 250 mm.
- 4.2.5 The outer surface of the guard shall be smooth, and so far as possible continuous from front to the rear.
- 4.2.6 Adjacent parts may overlap, provided that the overlapping edge faces rearwards or downwards or a gap of not more than 25mm measured longitudinally may be left, provided that the rearward part does not protrude outboard of the forward part.
- 4.2.7 Domed heads of bolts or rivets may protrude beyond the surface to a distance not exceeding 10 mm and other parts may protrude to the same extent provided that they are smooth and rounded.
- 4.2.8 The external edges and corners shall be rounded with a radius not less than 2.5 mm.
- 4.2.9 The device may consist of a continuous flat surface or of one or more horizontal rails or a combination of surface and rails.
- 4.2.10 The rails used shall be not more than 300 mm apart.
- 4.2.11 The rails used shall be not less than 50 mm high for vehicles having maximum mass less than 12 tons and trailers having maximum mass less than 10 tons.
- 4.2.12 The rails used shall be not less than 100 mm high for vehicles having maximum mass more than 12 tons and trailers having maximum mass more than 10 tons.
- 4.2.13 The forward edge of the side guard shall be constructed and positioned in such a way that it will comply with the following:
  - 4.2.13.1 On a motor vehicle: It shall not be more than 300 mm to the rear of the vertical plane perpendicular to the longitudinal plane of the vehicle and tangential to the outer surface of the tyre on the wheel immediately forward of the guard.

- 4.2.13.2 On a drawbar trailer: It shall not be more than 500 mm to the rear of the vertical plane perpendicular to the longitudinal plane of the trailer and tangential to the outer surface of the tyre on the wheel immediately forward of the guard.
- 4.2.13.3 On a semi-trailer: It shall not be more than 250 mm to the rear of the transverse median plane of the support legs, if support legs are fitted, but in any case the distance from the front edge to the transverse plane passing through the centre of the kingpin in its rearmost position may not exceed 2.7m. Construction:
- 4.2.13.4 When the forward edge of the guard lies in an open space, the edge shall consist of a continuous vertical member extending the whole height of the guard, the outer and forward faces of this vertical member shall measure at least 50 mm rearwards and be turned 100 mm inwards in the case of trucks having maximum mass of 3.5 tons to 12 tons and trailers having maximum mass of 3.5 tons to 10 tons.
- 4.2.13.5 The outer and forward faces of this vertical member in item 4.2.12.4 shall measure at least 100 mm rearwards and be turned 100 mm inwards in the case of trucks having maximum mass exceeding 12 tons and trailers having maximum mass exceeding 10 tons.
- 4.2.13.6 On a motor vehicle if the forward edge of the guard which is 300 mm dimension falls within the cab, the guard shall be so constructed that the gap between its forward edge and the cab panels does not exceed 100 mm and it shall be turned in through an angle not exceeding 45°.
- 4.2.13.7 On a motor vehicle if the forward edge of the guard which is 300 mm dimensions falls behind the cab and the side guard is extended forward to within 100 mm of the cab, then the provisions of the previous item shall be met.
- 4.2.14 The rearward edge of the side guard shall not be more than 300 mm forward of the vertical plane perpendicular to the longitudinal plane of the vehicle and tangential to the outer surface of the tyre on the wheel immediately to the rear.
- 4.2.15 The lower edge of the side guard shall be not more than 550 mm above the ground at any point.
- 4.2.16 The upper edge of the side guard shall not be more than 350 mm below that part of the structure of the vehicle, cut or contacted by a vertical plane tangential to the outer surface of the tyres, excluding any bulging close to the ground, except in the following cases.
- 4.2.16.1 Where the plane in the item 4.2.16 does not cut the structure of the vehicle, then the upper edge shall be level with the surface of the load-carrying platform, or 950 mm from the ground whichever is the less.
- 4.2.16.2 Where the plane in item 4.2.16 cuts the structure of the vehicle at a level more than 1.3 m above the ground, then the upper edge of the side guard shall not be less than 950 mm above the ground.
- 4.2.16.3 On a vehicle specially designed and constructed, and not merely adapted, for the carriage of a container or demountable body, the upper edge of the guard shall be determined in accordance with any one of the items (4.2.16.1 and 4.2.16.2) mentioned above.

- 4.2.17 Components permanently fixed to the vehicle, e.g. spare wheels, batterybox, air tanks, fuel tanks, lamps, reflectors and tool boxes may be incorporated in the guard, provided that they meet the dimensional requirements of this Regulation. The requirements of items from 4.2.5 to 4.2.8 shall generally apply as regards gaps between protective devices and permanently fixed components.
- 4.3 Design
- 4.3.1 The side guards shall be rigid and shall be mounted securely without any vibration in normal use of the vehicle.
- 4.3.2 The side guard shall be made of metal or any other suitable material.
- 4.4 The side guard shall not be used for the attachment of brake, air or hydraulic pipes.
- 4.5 Strength
- The guard shall be capable of withstanding a horizontal static force of 1 Kn applied perpendicularly to any part of its external surface by the centre of a ram the face of which is circular and flat and the deflection of the guard under load is not more than:
- 4.5.1 30 mm over the rearmost 250 mm of the guard.
- 4.5.2 150 mm over the remainder of the guard.
- 5- LABELLING AND MARKING
- 5.1 Each side guard shall be legibly and durably marked or labeled with the following information in Arabic and/or English.
- 5.1.1 Manufacturer's name and address.
- 5.1.2 Vehicle type for which the side guard is designed.
- 5.1.3 Brief description of the side guard e.g. dimensions and constituent materials.
- 5.1.4 Maximum mass.
- 6- TESTING
- 6.1 Sampling
- Two large side guard for truck and trailer shall be supplied and subjected to the required tests prescribed in this standard.
- 6.2 Measuring instruments
- 6.2.1 Dimensions measuring instrument:
- The instruments used shall permit measurement to an accuracy of  $\pm 1$  mm.
- 6.2.2 Force measuring instruments:
- The instruments used shall permit measurement to an accuracy of  $\pm 5\%$  of the range.
- 6.3 Tests
- The following tests shall be carried out on the side guard withdrawn in accordance with item 6.1.

### 6.3.1 Visual inspection

The side guard shall be visually inspected to check for damage, cracks, sharp edges, sharp corners, any other apparent defects in the manufacture.

### 6.3.2 Dimensions measurement

#### 6.3.2.1 Apparatus

Suitable measuring instruments shall be used for checking the dimensions of the side guard.

#### 6.3.2.2 Preparation for the test

- The vehicle shall be positioned on a horizontal and flat surface.
- The steered wheels shall be in a straight ahead position.
- The vehicle shall be unladen.
- Semi-trailers shall be positioned on their supports in an essentially horizontally manner.

#### 6.3.2.3 Procedure

The measurements shall be made on the side guard and the compliance with item 4 shall be checked.

### 6.3.3 Strength test

#### 6.3.3.1 Apparatus

The apparatus shall consists of a ram the face of which is circular and flat with a diameter of  $(220 \pm 10)$  mm.

#### 6.3.3.2 Preparation for the test

The vehicle shall be positioned for the tests as explained in item 6.3.2.2.

#### 6.3.3.3 Procedure

- The vehicle shall be positioned on a horizontal flat surface.
- The circular ram of diameter  $(220 \pm 10)$  mm shall be positioned at a point at 250 mm from the rear.
- A horizontal static force of 1 Kn shall be applied at this point.
- The deflection of the guard from the original fixed position shall be measured.
- The test shall be repeated at several points along the side guard and the deflection shall be measured.

## 7- CRITERIA OF TECHNICAL CONFORMITY

7.1 The criteria of technical conformity shall be in accordance with the Gulf Standard G.S. 48 "Motor Vehicles - Conformity Certificates",

7.2 The side guard shall be considered complying with all the requirements of this standard when the withdrawn sample from the consignment or the supplied sample passes the tests.

- 7.3 In case one or more side guard in the sample fails to pass the test, a second sample double the number of units as the first one shall be withdrawn from the same consignment or the supplied sample and subjected to the tests.

The side guard shall be considered complying with requirements of this standard when all the units of the second sample pass the tests, otherwise the side guard shall be considered non-complying.

المملكة العربية السعودية  
KINGDOM OF SAUDI ARABIA

الهيئة السعودية للمواصفات والمقاييس والجودة  
Saudi Standards, Metrology and Quality Org.(SASO)

**SASO GSO 2114:2012**

السيارات - حواجز الحماية الخلفية للشاحنات والمقطورات وطرق اختبارها

**Motor vehicles-rear under run protective devices for  
truck and trailer and its methods of test**



المواصفات القياسية السعودية  
SAUDI STANDARDS

**السيارات - حواجز الحماية الخلفية للشاحنات والمقطورات وطرق اختبارها**  
**Motor vehicles-rear under run protective devices for**  
**truck and trailer and its methods of test**

التصنيف الدولي للمواصفات

تاريخ الاعتماد من مجلس الإدارة : ١٤٣٤/٢/١٢ هـ الموافق ٢٠١٢/١٢/١٦ م  
تاريخ النشر في الجريدة الرسمية: ١٤٣٤/٤/٥ هـ الموافق ٢٠١٣/٢/١٦ م  
تاريخ العمل بلائحة : ١٤٣٥/٤/٥ هـ الموافق ٢٠١٤ / ٢ / ٦ م

Motor vehicles -  
Rear underrun protection in truck and  
Trailer and its methods of test

1- SCOPE AND FIELD OF APPLICATION

This standard is concerned with the requirements for the rear underrun protective devices (RUPD) of trucks and trailers having maximum mass exceeding 3.5 tones used for the carriage of goods. This standard does not apply to Traction units for articulated vehicles, special trailers constructed for the carriage of very long loads such as timber, steel bars etc.

2- COMPLEMENTARY REFERENCES

2.1 GSO 159 "Motor Vehicles - Weights and Dimensions".

2.2 GSO 48 "Motor Vehicles - Conformity Certificates".

3- DEFINITIONS

3.1 Unladen mass: The mass of the vehicle in running order, unoccupied, and unladen but complete with fuel, coolant, lubricant, tools and spare wheel.

3.2 Maximum mass: The mass stated by the vehicle manufacturer to be technically permissible.

3.3 Rear underrun protective device (RUPD): It consists of a cross-member and links to the chassis side members or other structural members of the vehicle.

3.4 Type of RUPD: RUPD which do not differ with respect to the essential characteristics such as shape, dimensions, attachment, materials and the marking.

3.5 Rear Underrun Protection (RUP) : The presence at the rear of the vehicle of either: a special RUPD or a body work, chassis parts or other components such that by virtue of their shape and characteristics, these elements can be regarded as totally or partially fulfilling the function of the RUPD.

4- REQUIREMENTS

The following shall be met:

4.1 General

4.1.1 All vehicles carrying goods, including tankers, mobile cranes, mobile workshops, trailers and semi-trailers shall be equipped with rear underrun protective devices to protect against underrunning of vehicles in the event of rear collision with passenger cars, multi-purpose vehicles and light duty trucks having a maximum mass not exceeding 3.5 tonnes.

4.1.2 The rear underrun protective device shall comply with the requirements specified in item 4.2.

4.1.3 If the vehicle is so designed and equipped at the rear that by virtue of their shape and characteristics, its component parts comply with the requirements specified in items 4.2 and 4.3, then the vehicle may not be necessary to be provided with rear underrun protective device.



- 4.1.4 The maximum mass of a vehicle type for which the rear underrun protective device to be installed shall not exceed the value indicated on the rear underrun protective device for which it is designed for.
- 4.2 RUPD Technical requirement
- 4.2.1 The section height of the RUPD member shall not be less than 100 mm.
- 4.2.2 The lateral extremities of the cross-member shall not bend to the rear or shall not have a sharp outer edge. This requirement can be considered as complied if the lateral extremities of the cross member are rounded on the outside and have a radius of curvature of not less than 2.5mm.
- 4.2.3 In case, if the rear underrun protective device is designed to have several positions at the rear of the vehicle, there must be a guaranteed method of securing it in the service position, and the force applied by the operator to vary the position of the device shall not exceed 40 daN.
- 4.2.4 The rear underrun protective device shall offer adequate resistance to forces applied parallel to the longitudinal axis of the vehicle.
- 4.2.5 When a horizontal force of 100 kN is applied to the rear underrun protective device, the distance between the rear of the rear underrun protective device and the rear extremity of the vehicle shall not exceed 400 mm at any of the points where the test forces are applied.
- 4.2.6 For vehicles fitted with a platform lift at the rear, the underrun device may be interrupted for the purposes of the mechanism. In this case, the following special requirements apply:
- 4.2.6.1 The maximum lateral clearance measured between the elements of the underrun device and the elements of the platform lift, which move through the interruption when the lift is operated and which make the interruption necessary, may amount to no more than 2.5 cm.
- 4.2.6.2 The individual elements of the underrun protection, including those outboard of the lift mechanism, where provided, must have an effective surface area, in each case, of at least 350 cm<sup>2</sup>. However, in the case of vehicles having a width of less than 2000 mm and where it is impossible to achieve the above requirement, the effective surface may be reduced on the condition that the resistance criteria are met.
- 4.3 Installation of RUPD indicated in item 4.2 to the vehicle
- 4.3.1 The ground clearance with respect to the underside of the protective device, even when the vehicle is unladen shall not exceed 550 mm over its entire width.
- 4.3.2 The height above the ground of the points of application of the test forces applied to the device shall not exceed 600 mm.
- 4.3.3 The width of the rear underrun protective device shall not at any point exceed the width of the rear axle measured at the outermost points of the wheels.
- 4.3.4 The width of the rear protective device shall not be more than 100 mm shorter on either side than the width of the rear axle measured at the outermost points of the wheels.

- 4.3.5 The device shall be so fitted that the horizontal distance between the rear of the device and the rear extremity of the vehicle, including any platform lift mechanism, shall not exceed 400 mm measured at any of the points where the test forces have been applied. In measuring this distance, any part of the vehicle which is more than 2 m above the ground when the vehicle is unladen shall be excluded.
- 4.3.6 The maximum mass of vehicle type for which the RUPD is installed shall not exceed the value indicated on the RUPD or with the approved document.
- 4.4 Requirements for Rear Underrun protection (RUP)
- 4.4.1 The ground clearance with respect to the underside of the RUP, even when the vehicle is unladen, shall not exceed 550 mm over its entire width.
- 4.4.2 The RUP shall be situated as close to the rear of the vehicle as possible.
- 4.4.3 The width of the RUP shall not at no point exceed the width of the rear axle measured at the outermost points of the wheels.
- 4.4.4 The width of the rear protective device shall not be more than 100 mm shorter on either side than the width of the rear axle measured at the outermost points of the wheels.
- 4.4.5 Where the device is contained in or comprised by the vehicle bodywork which itself extends beyond the width of the rear axle the requirement that the width of the RUP must not exceed that of the rear axle shall not apply.
- 4.4.6 The section height of the RUP shall not be less than 100 mm.
- 4.4.7 The lateral extremities of the RUP shall not bend to the rear or have a sharp outer edge. This requirement can be considered as complied when the lateral extremities of the RUP are rounded on the outside and have a radius of curvature of not less than 2.5 mm.
- 4.4.8 In case, if the rear underrun protection device (RUP) is designed to have several positions at the rear of the vehicle, there must be a guaranteed method of securing it in the service position, and the force applied by the operator to vary the position of the RUP shall not exceed 40 daN.
- 4.4.9 The RUP shall offer adequate resistance to forces applied parallel to the longitudinal axis of the vehicle and be connected, when in the service position, with the chassis side-members or whatever replaces them.
- 4.4.9.1 This requirement will be considered satisfied if it is shown that both during and after the application of the horizontal forces described in item 6.3, the horizontal distance between the rear of the RUP and the rear extremity of the vehicle, including any platform lift mechanism, does not exceed 400 mm at any of the points where the test forces are applied.
- 4.4.9.2 In measuring this distance, any part of the vehicle which is more than 2 m above the ground when the vehicle is unladen shall be excluded.
- 4.4.10 For vehicles fitted with a platform lift at the rear, the underrun device may be interrupted for the purposes of the mechanism. In this case, the following special requirements shall apply:

- 4.4.10.1 The maximum lateral clearance measured between the elements of the underrun device and the elements of the platform lift, which move through the interruption when the lift is operated and which make the interruption necessary, may amount to no more than 2.5 cm.
- 4.4.10.2 The individual elements of the underrun protection, including those outboard of the lift mechanism, where provided, shall have an effective surface area, in each case, of at least 350 cm<sup>2</sup>.
- 4.4.10.3 In the case of vehicles having a width of less than 2 000 mm and where it is impossible to achieve the above requirement, the effective surface area may be reduced on the condition that the resistance criteria are met.

## 5- MARKING

- 5.1 Each rear underrun protective device shall be legibly and durably marked or labelled with the following information in Arabic and/or English.
  - 5.1.1 Manufacturers name and/or trademark.
  - 5.1.2 Date of manufacture.
  - 5.1.3 The maximum mass of vehicle on which the rear underrun protective device may be installed.
  - 5.1.4 A detailed description with sketches the correct installation and adjustment of the device.
  - 5.1.5 Drawings, diagrams and layout plans of the components of the structure.

## 6- TESTING

### 6.1 Sampling

A sufficient number of rear underrun protective device shall be taken from the consignment of the devices of the same type and subjected to the required tests prescribed in this standard.

### 6.2 Measuring instruments

#### 6.2.1 Dimension measuring instrument

The instruments used shall permit measurement to an accuracy of ( $\pm 1$ ) mm.

#### 6.2.2 Force measuring instruments

The instruments used shall permit measurement to an accuracy of  $\pm 5\%$  of the range.

### 6.3 Tests

The following tests shall be carried out on the sample withdrawn in accordance with item 6.1.

#### 6.3.1 Visual inspection test

The rear underrun protective device shall be visually examined to check for any damage, crack, sharp outer edge or any apparent defects.

#### 6.3.2 Test conditions for RUPD

The test may be carried out either:

6.3.2.1 On a vehicle of the type for which RUPD is intended

6.3.2.2 On a part of the chassis of the vehicle type for which the RUPD is intended, this part shall be representative of the vehicle type in question

6.3.2.3 On a rigid test bench

6.3.3 Test conditions for vehicles.

- The sample shall be installed on to a vehicle of the type for which the rear underrun protective device is intended or part of the chassis or on a rigid bench.
- The vehicle shall be at rest on a level, flat, rigid and smooth surface.
- The front steered wheels shall be in the straight-ahead position.
- The vehicle shall be unladen.
- The tyres shall be inflated to the pressure recommended by the vehicle manufacturer.
- The vehicle shall be restrained by a suitable method as specified by the manufacturer to or restrained by any method specified by the manufacturer.
- If the rear underrun protective device is installed to a trailer, the trailer shall be coupled to the tractor.
- Vehicles equipped with hydropneumatic, hydraulic or pneumatic suspension or a device for automatic leveling according to load shall be tested in the normal running condition specified by the manufacturer.

6.3.4 Procedure

The measurements shall be made on the rear underrun protective device installed in accordance with item 6.3.2 and the compliance with items 4.2, 4.3 and 4.4 shall be checked.

6.3.5 Strength test

6.3.5.1 Apparatus

The apparatus shall consist of a suitable mandrel of maximum height 250 mm, 200 mm wide, with a radius of curvature of  $(5 \pm 1)$  mm at the vertical edges.

6.3.5.2 Preparation for the test

The vehicle shall be prepared for the tests as explained in item 6.3.3.

6.3.5.3 Procedure

6.3.5.3.1 The test vehicle shall be positioned on a horizontal flat surface.

6.3.5.3.2 The height of the mandrel shall be adjusted so that the height above the ground of the centre of the impact surface shall not exceed 600 mm.

6.3.5.3.3 A horizontal force of 100 kN or 50% of the force generated by the maximum mass of the vehicle, whichever is the lesser, shall be applied consecutively to two points

situated symmetrically about the centre line of the device or of the vehicle whichever is applicable at a distance of (700 to 1000) mm.

6.3.5.3.4 In the cases defined in items 6.3.2.1 and 6.3.2.2 a horizontal force of 50 kN or 25% of the force generated by the maximum mass of the vehicle, whichever is the lesser, shall be applied consecutively to two points located  $(300 \pm 25)$  mm from the longitudinal planes tangential to the outer edges of the wheels on the rear axle and to a third point located on the line joining these two points, in the median vertical plane of the vehicle.

6.3.5.3.5 In the cases defined in item 6.3.2.1 a horizontal force of 50 kN or 25 per cent of the force generated by the maximum mass of the vehicle for which the device is intended, whichever is the lesser, shall be applied consecutively to two points located by the manufacturer of the rear underrun protective device and to a third point located on the line joining these two points, in the median vertical plane of the device.

6.3.5.4 Replacement force application points:

If any point defined under item 6.3.5.1, is located within the interruption area of the underrun protection device as mentioned in paragraphs item 4.2.6 or 4.4.10 of this Regulation, the test forces shall be applied at replacement points located:

6.3.5.4.1 for the requirement under item 6.3.5.3.3, on the horizontal centerline and within 50 mm of each vertical edge closest to the intended points of force application, as defined in that paragraph, and

6.3.5.4.1 for the requirement under paragraph item 6.3.5.3.4, at the intersection of the horizontal and vertical centerlines of each element furthest from the vertical centerline of the device or of the vehicle, whichever is applicable. These points should be a maximum of 325 mm from the longitudinal planes tangential to the outer edges of the wheels on the rear axle.

6.3.5.5 Result

At the end of each test the distance between the rear of the rear underrun protective device and the rear extremity of the vehicle at any of the points shall be measured.

## 7- CRITERIA OF TECHNICAL CONFORMITY

7.1 The criteria of technical conformity shall be in accordance with the Gulf Standard G.S. 48/1984 "Motor Vehicles - Conformity Certificates".

7.2 The manufacturer of RUPD shall supply

7.2 The rear underrun protective device shall be considered complying with all the requirements of this standard when the withdrawn sample from the consignment or the supplied sample by the manufacturer passes the tests.

7.3 In case one or more rear underrun protective device in the sample fails to pass the tests, a second sample double the number of units as the first one shall be withdrawn from the same consignment or the supplied sample and subjected to the tests.

The rear underrun protective device shall be considered complying with the requirements of this standard when all the units of the second sample pass the tests, otherwise the rear underrun protective device shall be considered non-complying.